

ELECTRIC WIRE ROPE HOIST

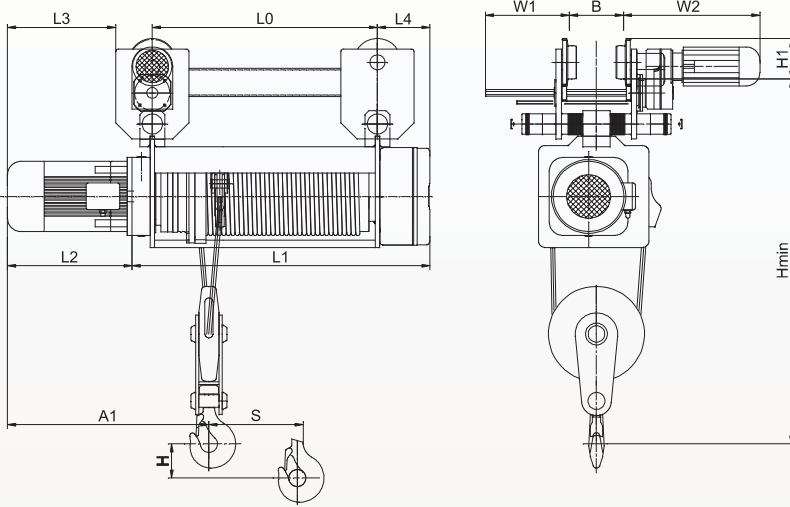
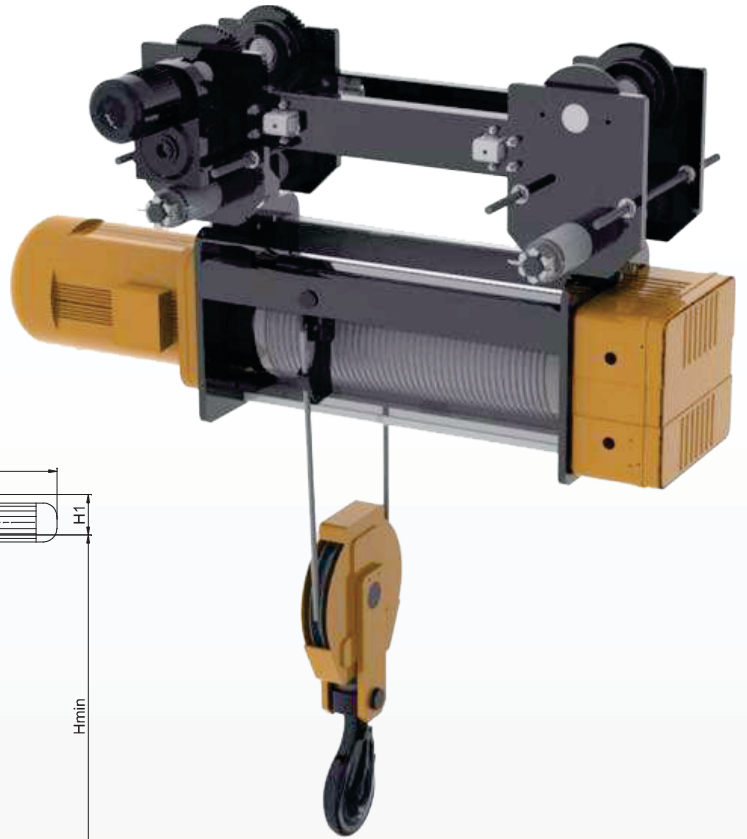

TECHNICAL SPECIFICATIONS

Model	SWL ton	Wire Rope mm	MH Speed m/min	MH Power kW	CT Speed m/min	CT Power kW	Dimensions								Height of Lift (m)						
							Hmin	W1	W2	H1	L2	L3	L4	A1	6	9	12	18	24	30	
SHA6-3B	1	7.4	8.4	1.5	20	0.37	950	316	498	121	302	233	139	518	L0	382	479	576	770	964	1158
															L1	584	681	778	972	1166	1360
															S	96	144	192	288	384	480
															Wt (kg)	280	290	300	320	340	360
SHA6-4B	2	11	7.2	3	20	0.37	1120	318	496	121	350	295	147	612	L0	458	562	716	924	1132	1340
															L1	667	772	925	1133	1341	1549
															S	104	156	209	313	417	521
															Wt (kg)	375	387	399	412	430	450
SHA6-5B	3.2	13	7.0	4.5	20	0.37	1215	318	496	121	380	313	168	646	L0	489	598	757	975	1193	1411
															L1	718	827	986	11204	1422	1640
															S	109	164	219	328	437	546
															Wt (kg)	450	460	475	505	535	560
SHA6-6B	5	15	7.6	7.5	20	0.55	1370	310	504	151	460	400	194	744	L0	523	638	832	1061	1290	1519
															L1	792	907	1101	1330	1559	1788
															S	1	177	229	344	458	572
															Wt (kg)	590	606	636	676	716	756
SHA6-7B	8	18	8.0	13	20	0.55	1520	305	509	179	520	481	211	868	L0	572	689	885	1118	1351	1584
															L1	888	1005	1201	1434	1667	1900
															S	116	175	233	350	466	583
															Wt (kg)	883	907	951	1008	1065	1123
SHA6-8B	10	18	6.4	13	20	0.75	1520	305	509	179	520	481	211	868	L0	572	689	885	1118	1351	1584
															L1	888	1005	1201	1434	1667	1900
															S	116	175	233	350	466	583
															Wt (kg)	895	920	974	1029	1084	1162